

La IV rivoluzione industriale



La casa del Chef

design stramigioli associati

ORE 08:00



365 la IV rivoluzione industriale. Una macchina assolutamente flessibile, un locale capace di adattarsi alle esigenze personali e al momento che si sta vivendo, sono queste le urgenze che muovono una nuova classe di imprenditori alla ricerca di soddisfazioni e di successo.

365: the 4th industrial revolution. An extremely flexible machine, a room able to suit your personal needs and up-to-date, these are the pressing prerogatives that push a new business class in search of fulfilment and success.



ORÉ 12:30



365 di Orion è il risultato di queste aspettative. La forma tangibile di ciò che fino a ieri era solo un desiderio e oggi è realtà. La tecnologia che anima 365 comunica un'idea travolgente, il pensiero di un modo nuovo di concepire il business.

As an Orion-branded product, 365 is the result of these expectations. Its tangible shape that was just a desire until yesterday it has now become reality. The technology of 365 cabinet puts across an overwhelming idea, the thought of a new way to conceive business.



ORE 19:00



Gli imprenditori che si affidano a 365 hanno a disposizione un prodotto coerente con la forza della loro creatività, la risposta piena al bisogno di performance.

Businessmen that rely on 365 have at their disposal a product which is consistent with their creativity, the right answer to the need of performance.



ORE 22:00



Le immagini che vi proponiamo ritraggono la 365 nella sua versatilità quotidiana, dalla praticità per la prima colazione all'eleganza della gelateria da gustare a fine giornata. 365 si distingue per il grande potenziale, voi distinguetevi scegliendola.

The following images show 365 in its daily versatility, ranging from the functionality for the early breakfast to the elegance of ice-cream to enjoy at the end of the day. 365 stands out for its great potential, you could stand out by choosing it.

Le nostre imprese sono l'espressione di passioni autentiche. I nostri locali raccontano quello che siamo: innovativi, eleganti, cordiali. Sono il teatro delle emozioni che ci accompagnano nel corso dei nostri giorni e mutano insieme a noi. E i mutamenti sono all'ordine del giorno.

The companies of our group are the expression of genuine passions. Our places tell what we are: innovative, smart, friendly. They are the scene of emotions of our everyday life and they change with us. Changes happen at any time of the day.



Come è possibile rendere più bello qualcosa che lo è già?
Rendendolo straordinario.

How can we make something beautiful if it is already nice? Just make it fantastic!



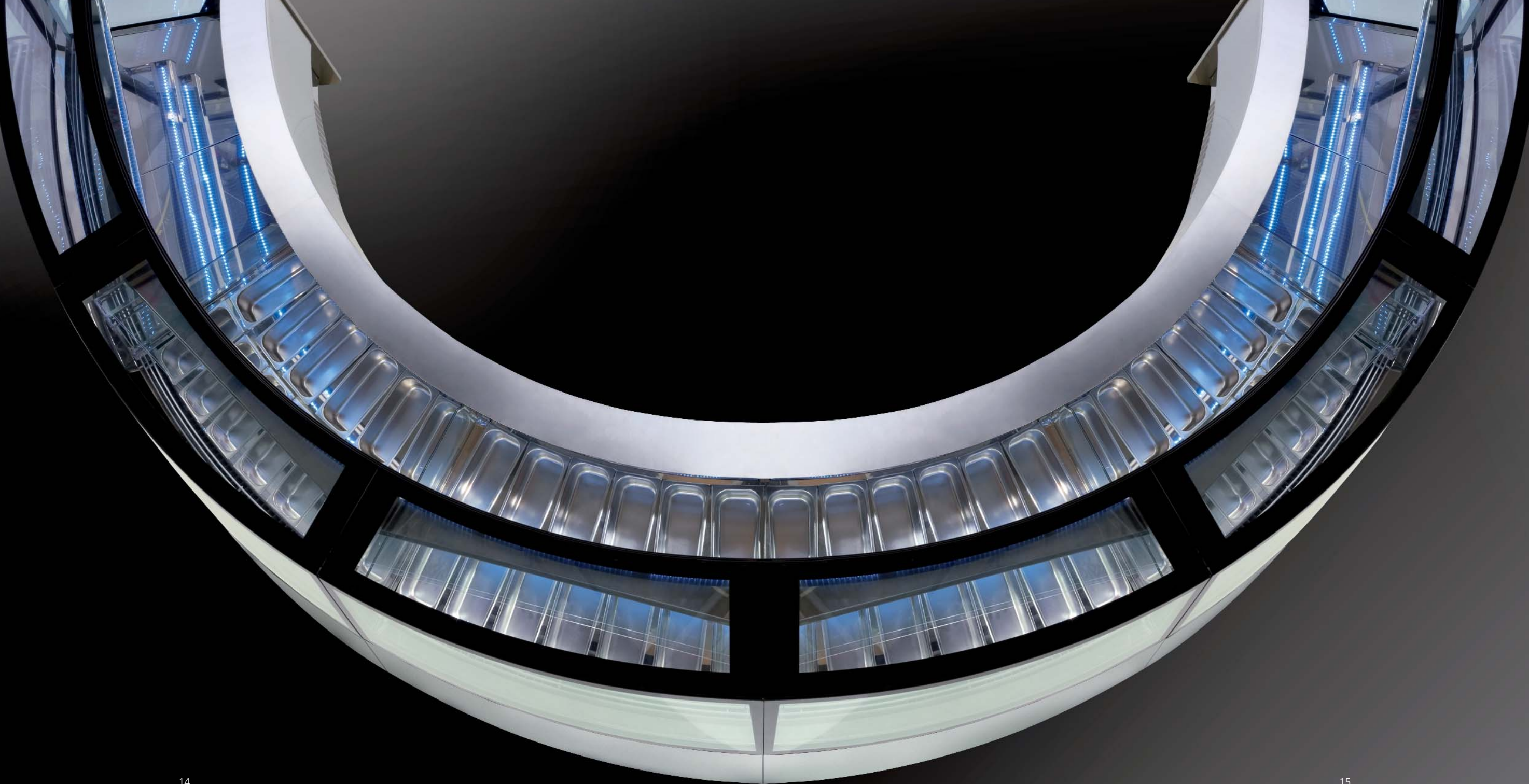



Da una grande esposizione per pasticceria a un'efficace vetrina gelato in meno di 5 min. e quattro mosse.

From a big displaying area for pastry to an effective ice cream cabinet in less than 5 min. and four moves.

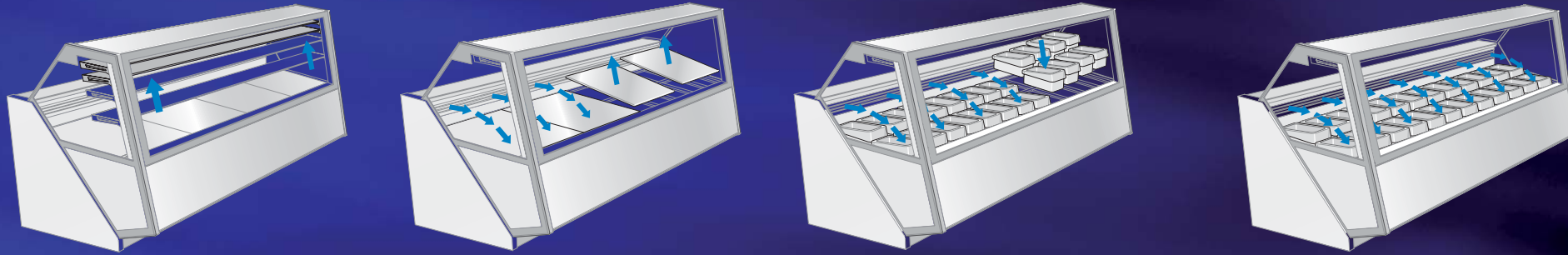

Con la schermata iniziale, spingere modalità d'uso.
Starting from the main screen, press directions for use.



Comparirà la videata **Modalità d'uso** con la richiesta di due opzioni. Tocca la funzione **Gelateria**.
Directions for use will be displayed together with the request of two options. Press the Ice Cream function.

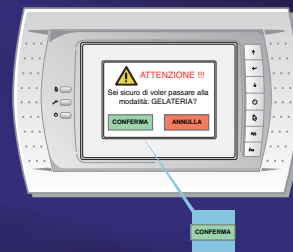

Il touch-screen (optional) chiederà la conferma della scelta. Toccando **Conferma** il motore aumenta la potenza per far scendere le temperature fino ai -20°. Rimuovete intanto i piani espositivi riponendoli negli appositi alloggi.

The touch-screen (optional) will ask you to confirm this selection. Press Ok. The engine increases the power to decrease temperature up to -20°. In the mean time remove the displaying boards by placing them in their appropriate seats.



Se necessario, inoltre, rimuovete le mensole seguendo la procedura indicata a pag. 24. Sistemate le vaschette gelato nella vetrina già predisposta per esporre il gelato. Con l'ultima videata controllerete la temperatura della vetrina che si fermerà a quella da voi scelta.

Furthermore, if necessary, remove the shelves by following the instructions on pag. 24. Place the tubs in the cabinet which is already prearranged to display ice cream. The last window displayed in the screen will enable you to check the temperature of the cabinet which can be adjusted according to your needs.

Gli ingegneri Orion lavorano per la passione della ricerca, la stessa che anima e che spinge a sempre nuove sperimentazioni. Con 365, si volta pagina, e si guarda al futuro.

Orion engineers work for passion, the same feeling that lights up and pushes to continuous new experimentations. With 365 you turn over and look to the future.

Al riparo da ogni evenienza, con la sicurezza attiva RCS.

Out of all eventualities, RCS: the active safety system.

Il sistema RCS (remote control system) consente di avere in qualsiasi momento la diagnosi dei principali parametri per il buon funzionamento della vetrina. RCS è la nuova tecnologia che Orion inserisce nella 365, completandola con un collegamento in rete che garantisce una continua assistenza dalla sede. Richiedete il sistema di controllo RCS e avrete la vetrina sempre nel pieno dell'efficienza.

RCS system (remote control system) allows you to have at any time the diagnosis of the main parameters for the good operation of the cabinet. RCS is the new technology that Orion applies to 365, implementing it by a net connection which guarantees a continuous service of the head office. Ask for RCS control system and you will always have a fully operational cabinet .

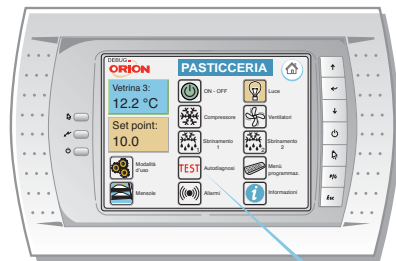

TEST

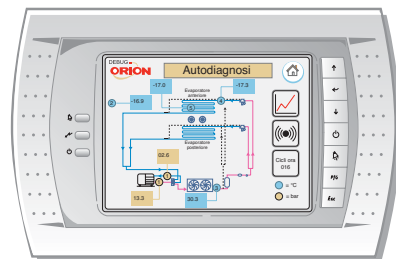

SU VETRINA - ON THE CABINET

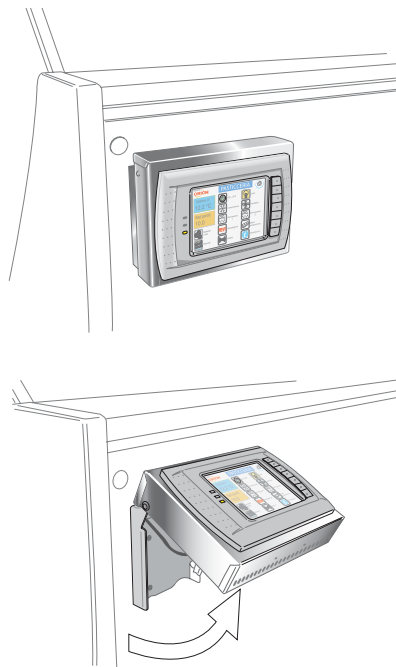

A PARETE - ON THE WALL





Una concezione di piani espositivi mai vista.

An unparalleled design of displaying tops.

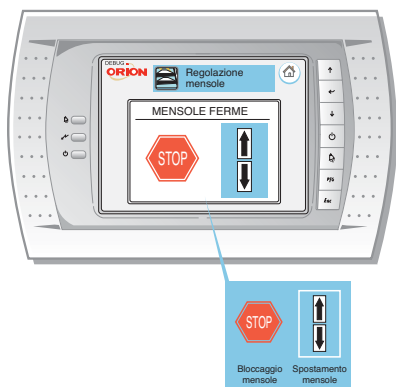

Bloccaggio mensole
Spostamento mensole

Il movimento delle mensole permette di giocare tra la visibilità dei prodotti e la capacità espositiva: in due minuti la 365 diventa ciò che vuoi.

Sarà sempre grazie al Touch-Screen (optional) scegliere quanta e quale esposizione avere nella vostra 365.

Basta toccare l'icona con le mensole e la schermata successiva ti consentirà di muovere le mensole con la pressione delle dita sulle frecce su/giù e fermarle dove decidete voi.

La stessa funzione può essere fatta anche con un normale quadretto elettronico fornito di serie.

The shelves movement allows you to play between the visibility of the products and the displaying capacity: in two minutes 365 becomes what you would like it to be.

All this thanks to the Touch-Screen panel (optional) Choose how much and which displaying area you would like to have in your 365.

You just need to touch the icon with shelves and in the following screen you will be able to move the shelves by pressing the up and down arrows and to stop them wherever you like .

The same function can also be carried out by a normal electric panel which comes equipped with the cabinet as standard.



365 aumenta il valore di libertà.

365 increases the value of freedom.

Gli esempi che vi offriamo in queste immagini declinano la 365 TS, in circa 50 modi differenti di esporre e conservare prodotti. Devi solo prendere una decisione.

In the TS version, each unit can be changed into a basis with more than 30 uses. The examples given in the following pictures show the 365 TS in over than 50 different ways to display and preserve products. You just have to make up your mind.



Funzioni espositive per professionisti.

Displaying functions for professionals.

Altezze diverse per utilizzi espositivi particolari, sempre la stessa tecnologia.
Different heights for particular displaying uses with the same technology.



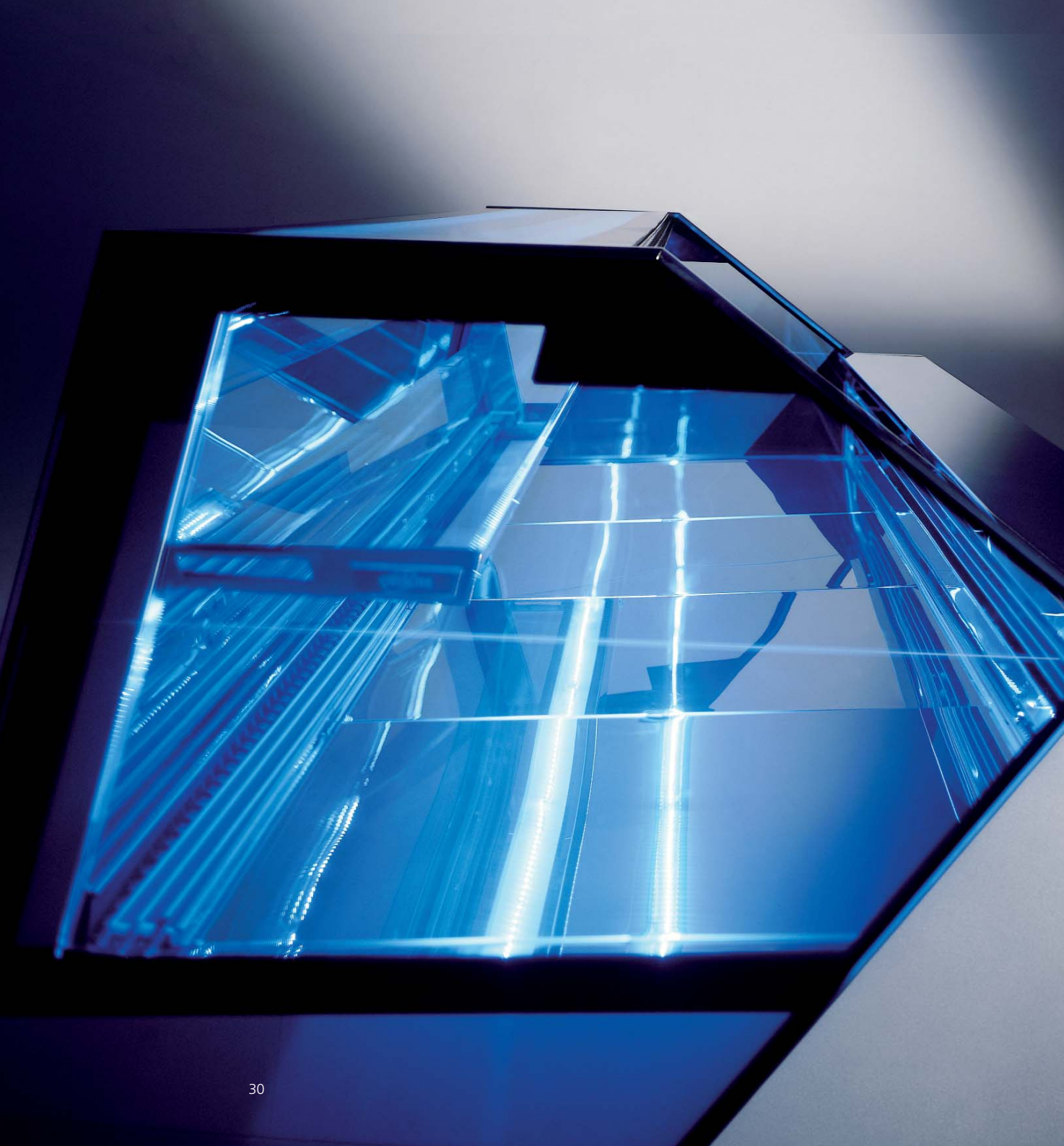



È la luce che indica la strada.

It's the light that shows the way.

Per questo abbiamo dotato la 365 di percorsi luminosi con Led di ultima generazione; per questo abbiamo deciso che l'innovazione fosse di serie.

This is why we have equipped 365 with luminous paths of state-of-the-art leds; we have made innovation be a production standard.



Immagine senza confini e
design senza compromessi.

Boundless image and design without compromises.

*I vetri si fondono in un'unica superficie, i colori diventano materia.
Glasses join into a single surface, colours become matter.*



Mai scontato.

Never predictable.

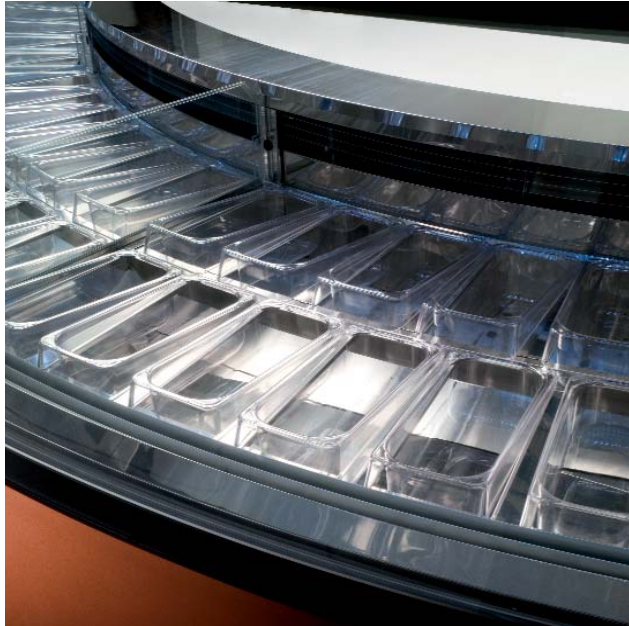

Una vaschetta trasparente si alza dal profilo d'appoggio e consente di conservare il gelato in posizione elevata. Aumentiamo comodità e visibilità, perché ogni particolare valorizzi i vostri prodotti.

A transparent tub rises from the support and allows you to preserve the ice cream on an elevated position. We have decided to increase comfort and visibility so that any detail may increase the value of your products.



Colori Orion 365.

Orion 365 colours.

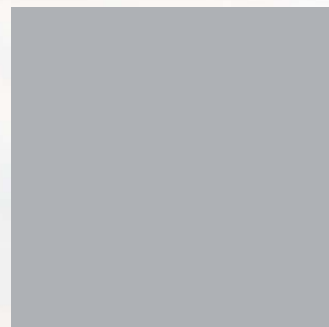

RAL 9006



RAL 1035



RAL 8029

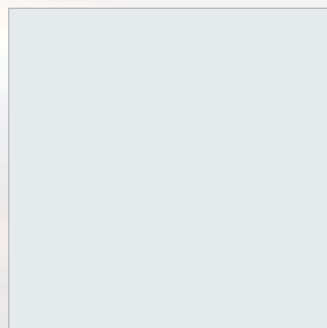

RAL 9003



365 GELATERIA 365 ICE-CREAM

ESTETICA E STRUTTURA AESTHETICS AND FRAMEWORK

Piano espositivo inclinato di 9°
9° inclined display area

Alloggiamento seconda fila di vaschette di scorta
Provision of second level of pans for storage

Castello vetri con montanti in alluminio rivestito di acciaio
Glass assemble with aluminium frame covered in steel

Vetro frontale doppio temperato riscaldato
Double tempered heated front glass

Apertura vetro frontale verso il basso
Top-down opening glass

Chiusura lato operatore a mezzo di pannelli scorrevoli in plexiglass
Operator's side closing by plexiglass sliding doors

Plafoniera di illuminazione a LED sul tettino e sulle mensole di esposizione
LED lighting system on the roof and shelves

Vaschette trasparenti con temperatura massima di lavaggio 60°C (opzionale)
Transparent pans with maximum washing temperature of 60°C (optional)

Mensole esposizione in vetro con possibilità di esclusione (compattatura verso il tettino) con movimento elettrico (escluso angolo). Disponibile solo nella versione TS
Glass shelves (close/hide to the roof option) electrically controlled (not available in the corner). Available only in the TS version

CAPACITA' ESPOSITIVA VASCHEFFE PAN DISPLAY CAPACITY

| | G6 | G9 | G12 | A30° | C30° | A45° |
|--|-------|-------|-------|-------|-------|------|
| N° vaschette standard 5 lt. (360x165x120H mm) N° of standard 5 lt. pans (360x165x120H mm) | 12+12 | 18+18 | 24+24 | 13+13 | 13+13 | 9+9 |
| N° vaschette grandi (360x250x120H mm) N° of big pans (360x250x120H mm) | 8+8 | 12+12 | 16+16 | 5+5 | 5+5 | 5+5 |
| N° vaschette trapezoidali N° of trapezoid pans | nd | nd | nd | 12+12 | 12+12 | nd |

TECNOLOGIA TECHNOLOGY

Impianto refrigerante standard con compressori semiermetici su unità condensatrici incorporate ad aria
Standard cooling system with semi-hermetic compressors on incorporated air-cooling condensing units

Impianto refrigerante con unità incorporata ad acqua o unità esterna ad aria o acqua (opzionale)
Cooling system with incorporated water-cooling or remote air or water-cooling condensing unit (optional)

Sbrinamento automatico ad inversione
Programmable cycle inversion automatic defrost

Sbrinamento automatico ad inversione (per gelateria) o a pausa (per pasticceria). Disponibile solo nella versione TS
Programmable cycle inversion automatic defrost (for ice cream) or pause defrost (for pastry). Available only in the TS version

Configurabile come gelateria o pasticceria
Configurable as ice cream or pastry cabinet

Pannello di controllo elettronico con termometro e termostato digitali
Electronic check panel with digital thermometer and thermostat

Pannello di controllo Touch screen con autodiagnosi (opzionale)
Touch screen check panel with autodiagnosis (optional)

Temperatura di esercizio standard a -18 ~ -20 °C
Standard working temperature at -18 ~ -20 °C

Temperatura di test 30°C / 55% UR (classe 4)
Testing temperature 30°C / 55% RH (class 4)

Alimentazione elettrica a 380volt / 3fasi / 50hz o 60hz
Electrical supply at 380volts / 3phases / 50hz or 60hz

Gas refrigerante R404a
Refrigerant gas R404a

| | G6 | G9 | G12 | A30° | C30° | A45° |
|---|--------|--------|--------|--------|--------|--------|
| Resa (W) Yield (W) | 1550 | 2300 | 2900 | 1550 | 1550 | 1200 |
| Potenza assorbita (W) Power absorption (W) | 1780 | 2930 | 3610 | 1990 | 1790 | 2020 |
| Peso netto Net Weight | 330 kg | 420 kg | 500 kg | 380 kg | 380 kg | 300 kg |

365 DIMENSIONI MODULI 365 MODULE DIMENSIONS

365 H 1400/1250 A30 GELATERIA

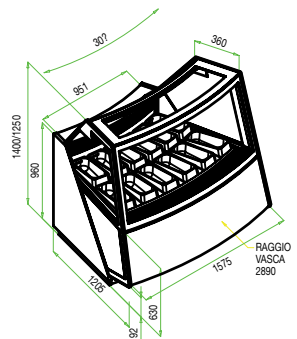

365 H 1400/1250 A30 PASTICCERIA

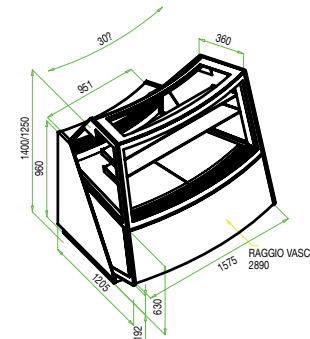

365 H 1400/1250 A45 GELATERIA

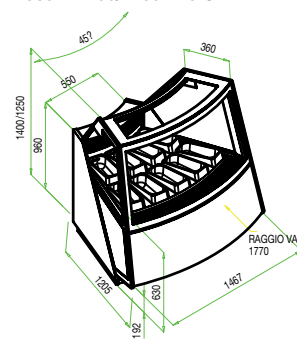

365 H 1400/1250 A45 PASTICCERIA

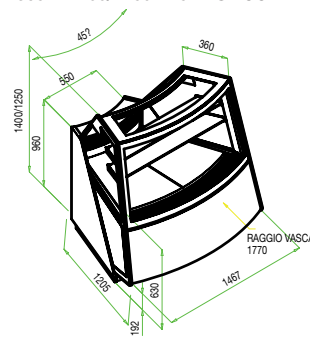

365 H 1400/1250 C30 GELATERIA

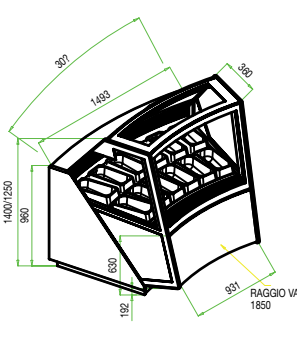

365 H 1400/1250 C30 PASTICCERIA

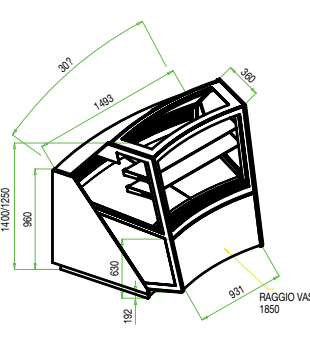

365 H 1400/1250 LINEARE GELATERIA

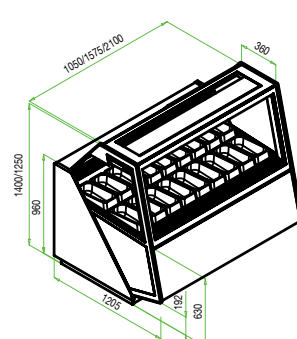

365 H 1400/1250 LINEARE PASTICCERIA

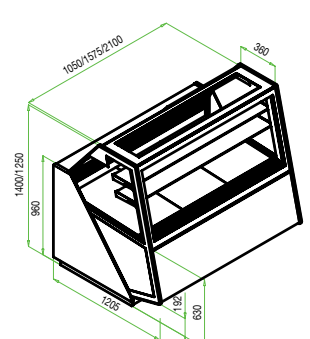

365 PASTICCERIA... ed altro 365 PASTRY... and more

ESTETICA E STRUTTURA AESTHETICS AND FRAMEWORK

Castello vetri con montanti in alluminio rivestito di acciaio
Glass assemble with aluminium frame covered in steel

Vetro frontale doppio temperato
Double tempered front glass

Apertura vetro frontale verso il basso
Top-down opening glass

Chiusura lato operatore a mezzo di pannelli scorrevoli in plexiglass
Operator's side closing by plexiglass sliding door

Plafoniera di illuminazione a LED sul tettino e sulle mensole di esposizione
LED lighting system on the roof and shelves

TECNOLOGIA TECHNOLOGY

Impianto refrigerante standard con compressori ermetici su unità condensatrici incorporate ad aria
Standard cooling system with hermetic compressors on incorporated air-cooling condensing units

Impianto refrigerante con unità incorporata ad acqua o unità esterna ad aria o acqua (opzionale)
Cooling system with incorporated water-cooling or remote air or water-cooling condensing unit (optional)

Impianto refrigerante con compressori semiermetici esterni (opzionale)
Cooling system with remote semi-hermetic condensing unit (optional)

Sbrinamento automatico a pausa
Programmable pause automatic defrost

Pannello di controllo elettronico con termometro e termostato digitali
Electronic check panel with digital thermometer and thermostat

Pannello di controllo Touch screen con autodiagnosi (opzionale)
Touch screen check panel with autodiagnosis (optional)

Temperatura di esercizio standard configurazioni refrigerate a +4 ~ +10 °C
Standard working temperature of refrigerated configurations at +4 ~ +10 °C

Temperatura di esercizio standard configurazioni tavole calde a +60 °C
Standard working temperature of dell hot configurations at +60 °C

Temperatura di test 30°C / 55% UR (classe 4)
Testing temperature 30°C / 55% RH (class 4)

Alimentazione elettrica a 220volt / 1fase / 50hz o 60hz
Electrical supply at 220volts / 1phase / 50hz or 60hz

Gas refrigerante R404a
Refrigerant gas R404a

CONFIGURAZIONI 365, 1400 - 1250 CONFIGURATIONS 365, 1400 - 1250

| MODELLO | ventilata ventilated | ventilata c/cassettoni ventilated with drawer | statica static | praline praline | tavola fredda deli | tavola calda hot deli | bagnomaria bain marie | neutra neutral |
|---------|----------------------|---|----------------|-----------------|--------------------|-----------------------|-----------------------|----------------|
| 2M | ■ | ■ | ■ | ■ | ■ | ■ | / | ■ |
| 3M | ■ | ■ | ■ | ■ | ■ | ■ | ■ | ■ |
| 4M | ■ | ■ | ■ | ■ | ■ | / | / | ■ |
| A 30 | ■ | / | / | / | / | / | / | / |
| C 30 | ■ | / | / | / | / | / | / | / |
| A 45 | ■ | / | / | / | / | / | / | / |

legenda: ■ di serie/standard / non disponibile/not available

art direction
LIFE

progetto grafico
LIFE

fotografia
LIFE

selezioni
DEF

stampa
SE.GRAF



ORION

Tel.: 942 60 52 72
www.lacasadelchef.net

